

Multi-Fit Floor Access Door



Key Features

- Elegant 4mm aluminium edges blend discreetly with floor finishes
- Easy removal with four corner locking/lifting positions and stainless steel locking bolts and dust-caps as standard
- Frame only 50mm deep. Light weight tray design suitable for floor finishes of up to 15mm thickness
- High performance triple EPDM seals for liquid, odour and dust-tight applications
- Reinforced for long term durability and performance
- Two lifting/locking keys and installation manual provided with each access cover

Our **Floor Door Access Panel** range provides a **high-quality finish** and **easy access** to **underlying services** and ducting. All products are fitted with both **liquid and odour tight EPDM seals** as standard and created to blend perfectly with a wide selection of both **hard** and **flexible floor infills** of thickness **up to 15mm**. Our range of **recessed floor door access panels** are designed for **internal and external applications** associated with both commercial, private and public sector buildings. Typical applications include areas used by **pedestrians, light vehicle traffic** and **heavier traffic** such as forklifts.

High quality aluminium single recessed floor access covers with a **frame depth of only 50mm**. Ideal for pedestrian, **trolley and light duty car/van** traffic applications where installation depths are restricted. Wide range of **size options** available for **clear openings** of between 300mm and 750mm. **Manual lift** single recessed cover option available. All covers fitted with **EPDM liquid, odour and dust seals** as standard with **four point stainless steel locking**. With a comprehensive range of **standard clear opening sizes** from 200 to 750mm. Our **Multi-Fit, Quick-Fit** and **Vinyl-Fit** floor access hatch covers are manufactured using **recycled materials** and at the end of life can be **100% recycled** contributing to a **sustainable environment** and **building practices**.

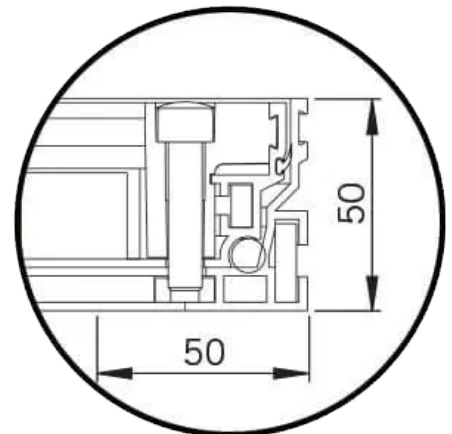
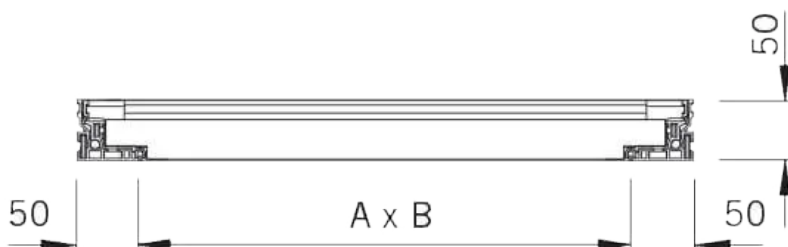

Contact us for a factory tour or to arrange an on site demonstration



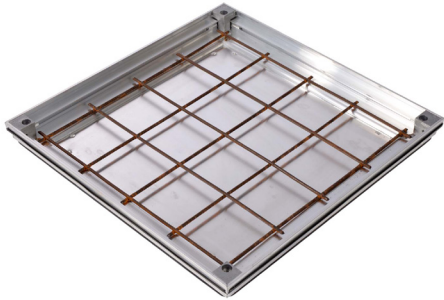

Benefits

High performance **triple sealed** for **liquid, odour** and **dust-tight** applications. Blends perfectly with both **hard** and **flexible** floor infills of thickness **up to 15mm**. Secure four point stainless steel locking. Wide range of cover sizes available for clear openings from **300mm** to **750mm**.

Suitable Flooring Types

The flooring types that we would recommend as the most suitable for these panels include: **Concrete, Epoxy, Terrazzo, Stone** and **Ceramic Tiles, Carpet** and **Wood**.

Ideal Applications

These **Multi-Fit Floor Door Access Panels** are ideal for a range of environments. Including but not limited to: **Shopping Centres, Offices, Hospitals, Schools, Leisure Facilities** and **Swimming Pools**.

Availability

These panels are available with the standard sizes (as shown below). Bespoke sizes available, for current lead times and more information please call or email our **Technical Sales Team**.

Standard Sizes		
300 x 300	450 x 450	600 x 450
600 x 600	750 x 600	

Mortar and Concrete Specifications

To enable covers to carry their intended service loads, the following minimum material specifications must be used or exceeded.

Frame bedding mortar-minimum class **M6** to **BS EN 998-2:2016**.

Frame haunch and recessed cover structural infill concrete - minimum grade **C35/45** concrete to **BS EN 206:2013** (maximum aggregate size **10mm**).

If access covers are to be used in a wet area, waterproofing additives may be required. Fast-curing cementitious mortars or concrete may be used as long as the performance is at least equivalent to those stated above. The concrete specified must not be replaced by screed.

Maintenance

All access covers and frames must be inspected every six months for any damage or wear which may impede their service performance. In order to carry out this inspection the covers must be opened/removed. This aids inspection and also helps keep opening mechanisms and gas springs where fitted in good working order.

During inspection it is recommended that all components are cleaned with a mild detergent and water. All seals, hinges and locking screws should be coated and lubricated with a suitable silicone grease. Finally replace any damaged or worn components.

Online Support

See website for **fitting guides** and **videos**. **DXF, DWG, CAD, PDF, BIM cross-section drawings** and full technical specifications.

Contact us for a factory tour or to arrange an on site demonstration

